

ASG SUPERCONDUCTORS

COMPANY PROFILE

2018

www.asgsuperconductors.com

ASG Superconductors is a leading Italian Company active worldwide in the **SUPERCONDUCTING** magnet and technology business for research and industrial applications

ASG has an average turnover of 50 M€/year consolidated and currently employs 230 highly specialized managers, engineers and technicians

Competences and ability to work with cutting edge technology and hi-tech materials is combined everyday with a strong commitment to increase production capability and technological skills, collaborating worldwide with the main scientific research institutes and with sector's market leaders.

ASG Superconductors is now organized in three operative units: **magnets & systems unit**, **columbus mgb2 unit** and **paramed mri unit** with 38,000 m² production over 4 plants in Liguria

THE RECENT MERGER HAS CREATED AN INDIVIDUAL COMPANY ABLE TO MASTER THE SUPERCONDUCTING TECHNOLOGY FROM THE MATERIAL SYNTHESIS TO THE COMMERCIALIZATION OF COMPLETE DEVICES

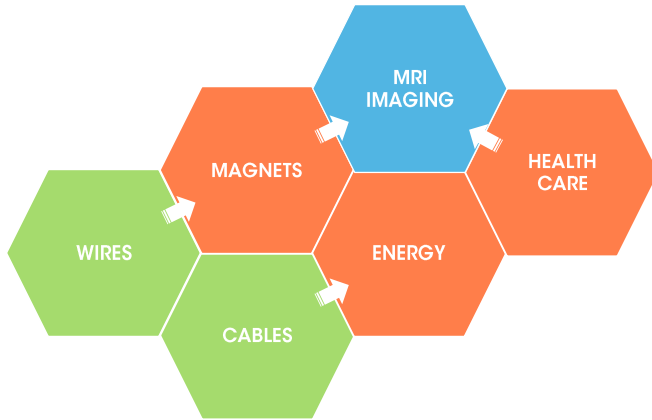

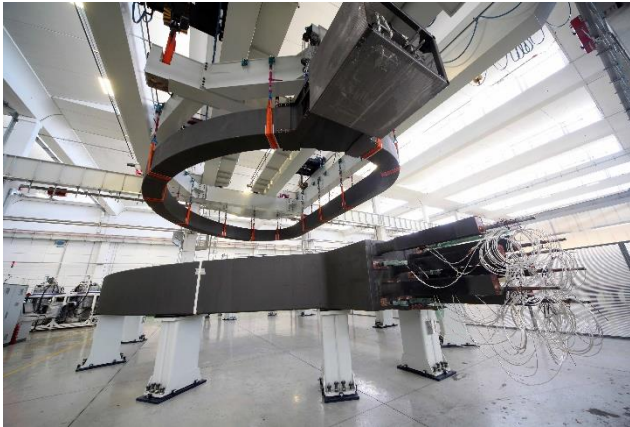
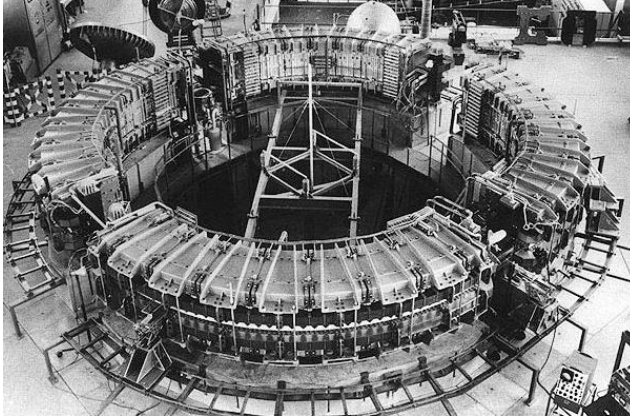

ASG's history is that of an **EXCELLENCE AT THE FOREFRONT OF TECHNOLOGY**

From research to industrial applications: starting as early as the 1950s - when the magnet unit of Ansaldo took part in the construction of the Italy's first electrosynchrotron in Frascati (Rome)

In 2001 the superconducting magnets division of Ansaldo spun-off as an independent company, increasing its effort significantly to become a sustainable market player, with a stronger inclination to develop new business opportunities by investing in promising materials including MgB_2 wires and in medical devices as MRI scanners

CERN, Fermilab, GSI, ITER - Fusion for Energy, CNAO and many more: ASG's history is a 50 years long legacy of facing and solving novel challenges presented by the scientific community

ASG ENGINEERS BELIEVE THAT IT IS NOW TIME TO BRING THEIR SUPERCONDUCTING TECHNOLOGY TO A HIGHER LEVEL, MAKING IT AVAILABLE FOR A COUNTLESS NUMBER OF ELECTROTECHNICAL DEVICES, WITH POSITIVE IMPLICATIONS ON A VARIETY OF ENERGY, MEDICAL AND INDUSTRIAL USES

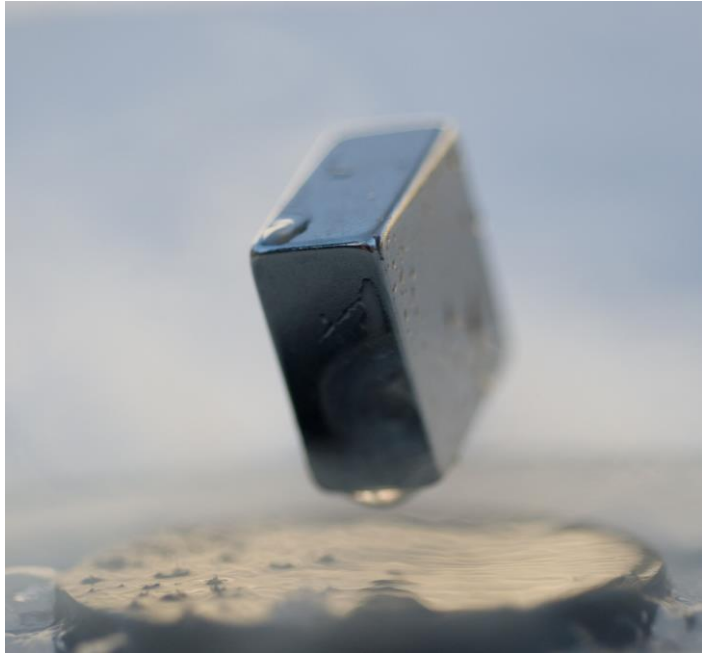

Superconductivity – even though discovered in 1911 – is one of the very few macroscopic evidence of quantum physics, and until today it is still largely unexploited at industrial level.

Superconducting materials allow for a truly “loss-less” transport of electrical currents when cooled to extremely cold temperatures.

Today, superconductivity finds application mainly in the medical sector, both in diagnostics (MRI) and in therapy (proton irradiation of cancer).

Recent progresses of the cryogenic industry and in the superconducting materials processing are greatly simplifying the use of ASG technology, bringing it much closer to conventional devices.

ASG has developed a new superconducting material, whose chemical formula is MgB_2 , to manufacture superconducting wires through an industrial process. MgB_2 distinguishes itself by the relatively high operating temperature, between 15 and 25K, the sole need of industry standards to synthesize it, and the processing through a rather conventional thermo-mechanical method into long, multifilamentary wires.

ASG ENGINEERS ARE FULLY ENGAGED IN THE RACE TO BRING SUPERCONDUCTIVITY CLOSER TO THE PEOPLE THAN IT IS TODAY , BY GENERATING, STORING, PROTECTING, AND FEEDING THE CLEAN ENERGY THEY NEED, BY IMPROVING THE MEDICAL TOOLS THEY MAY NEED DURING THEIR LIFE....

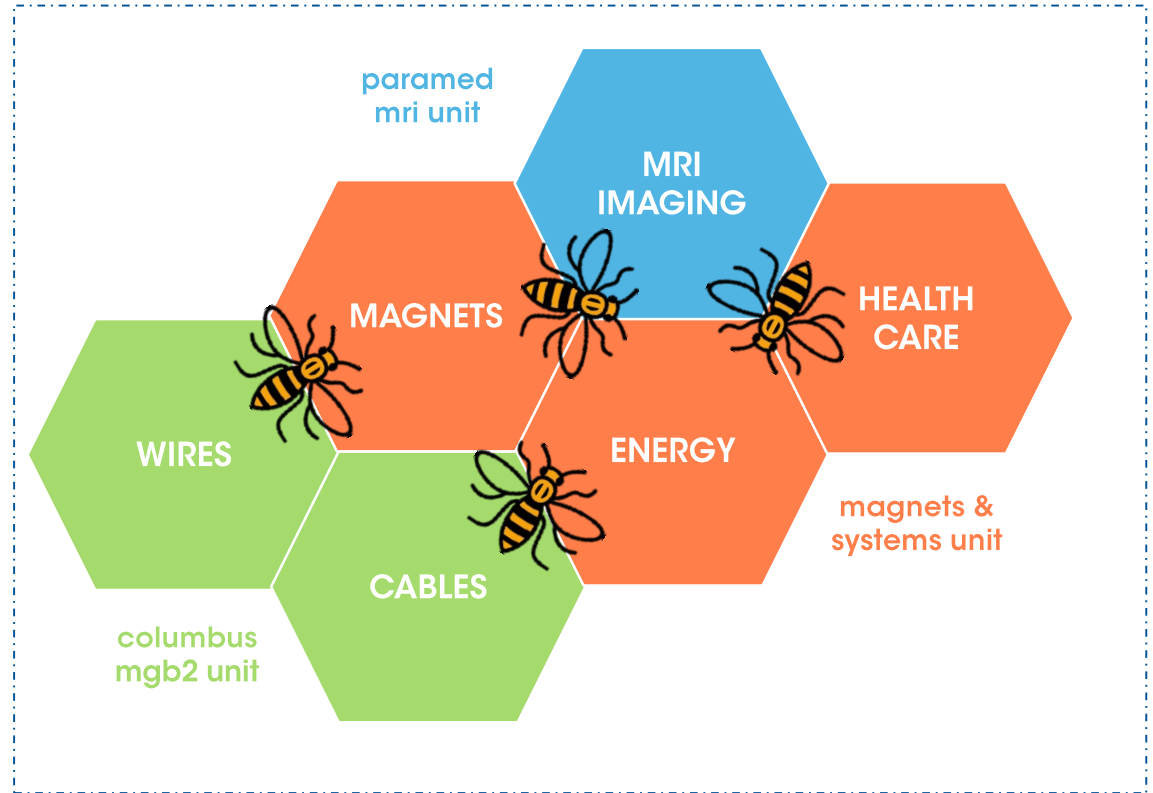

WORKING TOGETHER TO SQUEEZE THE BEST OUT OF OUR TECHNOLOGIES

With more than 50 years experience and with a vast and trusted global track record, the Magnets & Systems Unit designs, manufactures, and tests **SUPERCONDUCTING MAGNETS** and **SYSTEMS** for:

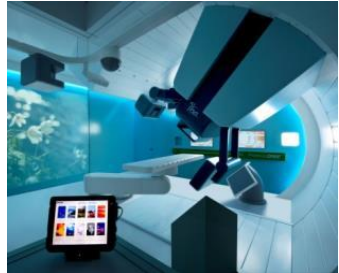
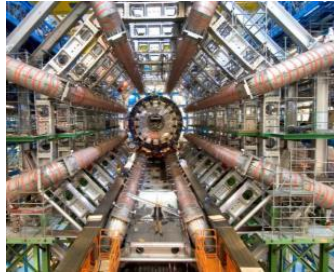

THERMONUCLEAR FUSION

HIGH ENERGY PHYSICS EXPERIMENTS

MRI MAGNETS

CANCER THERAPY MAGNETS

POWER GRID DEVICES

Superconducting magnets in thermonuclear fusion are essentially employed to **PRODUCE A STRONG MAGNETIC FIELD THAT LEVITATES AN EXTREMELY HOT PLASMA ROTATING IN A VACUUM CHAMBER**

ASG has been proudly selected to supply superconducting **MAGNETS TO ALL THE MOST IMPORTANT NUCLEAR FUSION INITIATIVES WORLDWIDE**

In turn delivering magnet systems for

- **STELLARATOR**
- **TOKAMAK**

And all orders of magnets:

- **CENTRAL SOLENOID**
- **TOROIDAL FIELD COILS**
- **POLOIDAL FIELD COILS**
- **DIVERTOR COILS**

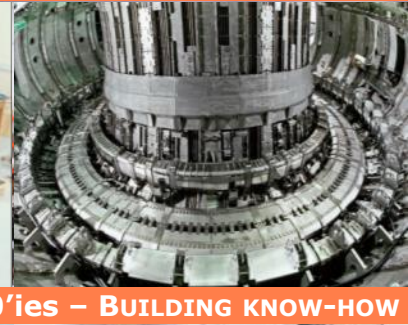
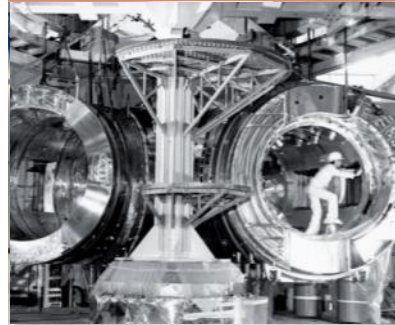

90'ies – BUILDING KNOW-HOW

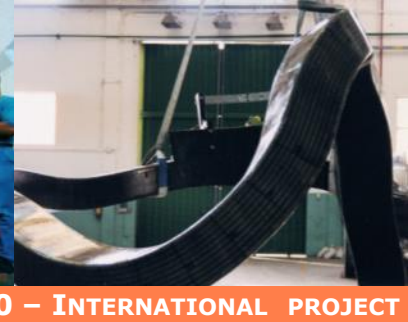

2000 – INTERNATIONAL PROJECT

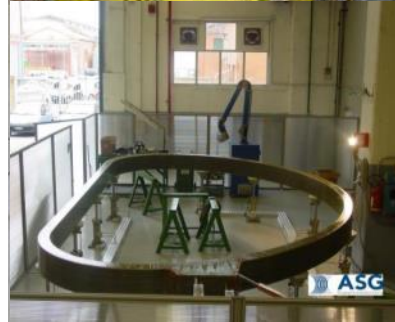

2010 – BIG PROJECTS: ITER & JT60

Superconducting magnets are **USED TO GUIDE AND FOCUS CHARGED PARTICLE BEAMS WITH A MINIMAL USE OF ENERGY**. They are also used in detectors to allow the **ANALYSIS OF THE OUTCOMES OF PARTICLE COLLISIONS**

ASG has been engaged in supplying both **LARGE SERIES PRODUCTION** as well as **ONE-OF-A-KIND MAGNETS** for a variety of experiments globally

ASG is regularly **IMPROVING ITS NUMERICAL MODELLING AND MANUFACTURING TOOLS** to follow the progress of the superconducting technology and the increase in system performance that the high energy physics community is perpetually seeking



90'ies

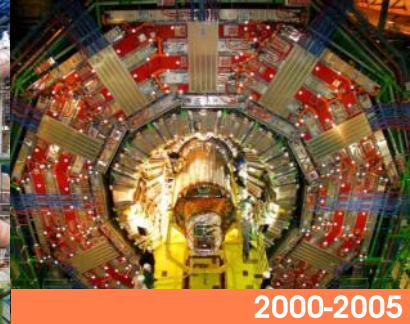
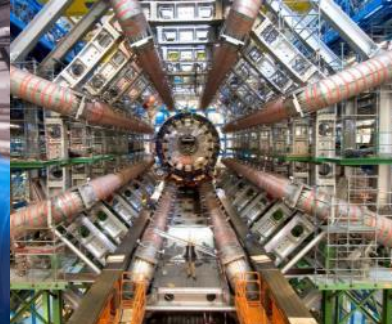

2000-2005

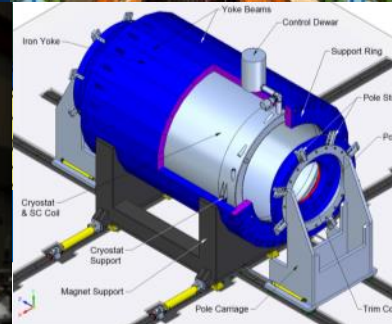
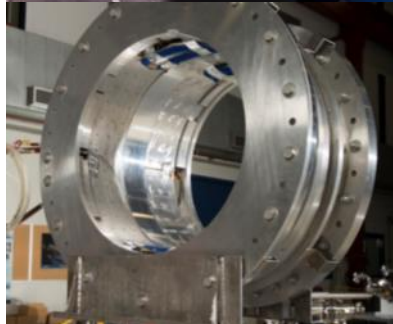

2015-2020

MRI imaging devices are the **MAIN DRIVER TODAY FOR THE SUPERCONDUCTING MAGNET BUSINESS**, with several thousands of units sold globally per year

ASG has developed a number of **MRI SOLUTIONS TO MEET SPECIFIC MRI MARKET DEMANDS**, including **HELIUM-FREE SYSTEMS, ULTRA-HIGH FIELD MAGNETS, IMAGE-GUIDED RADIATION THERAPY MAGNETS**

ASG is **MAKING USE OF COMPETENCES GAINED IN HIGH ENERGY PHYSICS AND FUSION** and **APPLYING THEM TO COMPACT ACCELERATORS FOR CANCER THERAPY WITH PROTON BEAMS**



14T



17.6T



7T



11.74T



0.5T



Ultra High Fields

0,5



Thanks to the negligible electrical resistance, superconductors make electrical devices **MORE EFFICIENT, COMPACT, POWERFUL THAN CONVENTIONAL EQUIVALENTS.**

To make their implementation in practice possible, at ASG we are developing technologies to **MODEL AND MANUFACTURE ENERGY-RELATED SUPERCONDUCTING DEVICES**, including **FAULT CURRENT LIMITERS (SFCL), MAGNETIC ENERGY STORAGE (SMES), WIND AND WAVE GENERATORS**

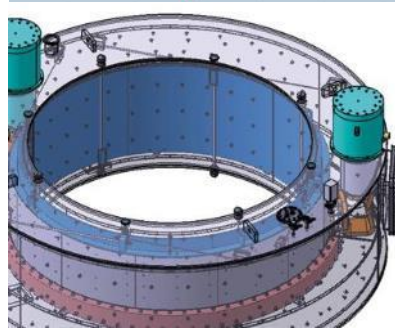
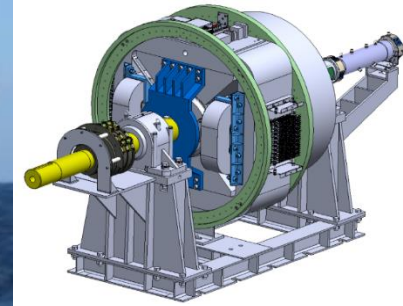

POWER QUALITY

COLUMBUS MgB₂ WIRE UNIT

Columbus MgB₂ unit is a **WORLD LEADER IN CUTTING-EDGE MAGNESIUM DIBORIDE (MgB₂) TECHNOLOGY** and the transformation of this superconducting material into long, versatile and **HIGHLY RELIABLE SUPERCONDUCTING WIRE**.

MgB₂ is one of the most recent solutions adopted by the superconductor industry, the high superconducting temperature (T_c= 40 K) means that MgB₂-based systems can be cooled by modern cryocooling devices, without the costly, problematic and hazardous use of liquid helium.

MgB₂ wire technology is already tested and used in energy, power, medical and high energy physics.

MGB2 WIRES FOR CABLES

MGB2 WIRES FOR MAGNETS

MGB2 WIRES FOR MRI

MGB2 CABLES

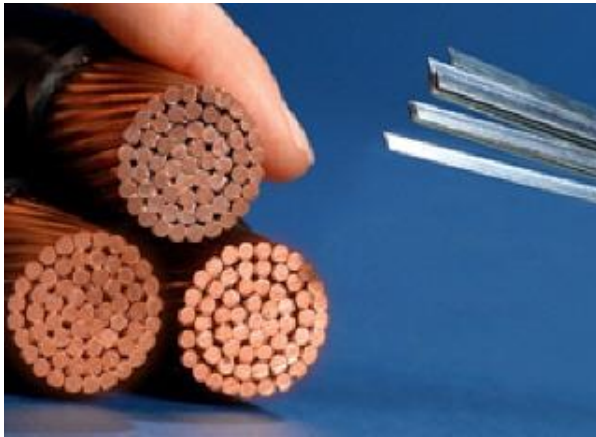

MgB_2 – a simple magnesium - boron alloy - has been recently discovered as a Superconductor.

It is potentially competitive over the present NbTi technology thanks to:

- **HIGHER** superconducting temperature
- Abundancy of its constituents
- Non-toxic
- **CAPABILITY TO CARRY 1000X CURRENTS THAN COPPER** through the same section

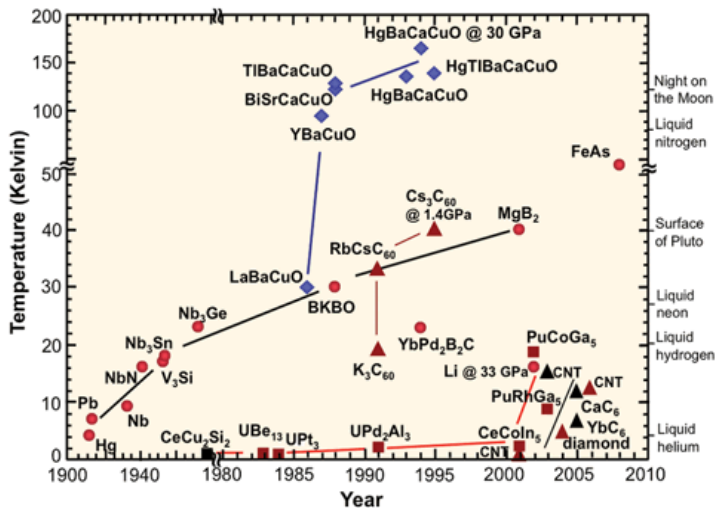

We have developed an **INDUSTRIAL PROCESS TO PRODUCE MgB_2 INTO LONG, ROBUST AND VERSATILE WIRES**

SIMPLIFIED OPERATION WITH MgB_2

HIGHER TEMPERATURE OF MgB_2 > **INNOVATIVE COOLING** of devices, making it much more **USER FRIENDLY**



There is no need to use any expensive, hazardous liquid coolant to maintain MgB_2 **IN OPERATING CONDITIONS**





	CABLES	ROTATING MACHINES (MOTORS/ GENERATORS)	MAGNETS	FAULT CURRENT LIMITERS	ENERGY STORAGE DEVICES
MEDICAL			✓		
ELECTRICITY/ GRID	✓			✓	✓
INDUSTRIAL	✓		✓		✓
AIRCRAFT/ AEROSPACE	✓	✓			
ENERGY GENERATION		✓			
NAVAL		✓		✓	

Ø 10 cm MgB₂ instead of Ø 1 m copper



90 tons, full MgB₂ 10MW wind turbine design

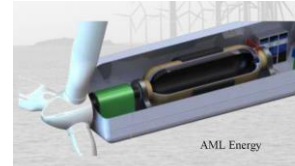

Ø 30 cm MgB₂ HVDC 6.4 GW power cable

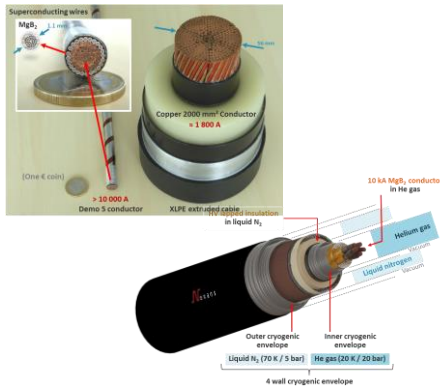

We do have sufficient MgB₂ wire manufacturing capability and device design and construction to realize full-scale systems

REDUCE LOSSES OF
CONVENTIONAL
SYSTEMS

CERN, DATA CENTERS,
SMELTERS, MRI &
THERAPY,..

POWER SCALE-UP OF
CONVENTIONAL
SYSTEMS

HVDC CABLES, 10MW+
WIND,
HV FCL,..

INTRODUCE RADICALLY
NEW DEVICES

IRONLESS MOTORS &
GENERATORS, SMES,
HEATERS, SEPARATORS,
ELECTRIC AIRCRAFTS,..

HIGHER EFFICIENCY

REDUCED FOOTPRINT

REDUCED WEIGHT

PARAMED MRI UNIT

Paramed MRI unit designs and produces **OPEN MRI SYSTEMS** with unique features and benefits, providing **OUTSTANDING PERFORMANCE AND UNPARALLELED PATIENT COMFORT.**

The company's flagship product, the MROpen system, is the only superconductive MRI with a "totally open" magnet design, that allows Multi-position imaging including advanced weight-bearing and functional studies, besides providing the highest comfort for patients.

We work for:

PLEASANT PATIENT EXPERIENCE

MORE EFFECTIVE HEALTHCARE

BETTER HEALTH

IMPROVING PEOPLE'S LIFE is our mission.
We achieve this through **INNOVATION, CREATIVITY AND PASSION.**



USA SUBSIDIARY IN CHICAGO

OPERATING IN 22 COUNTRIES

250 MRI UNITS INSTALLED WORLDWIDE



- 📍 Musculoskeletal MRI
- 📍 Upright "Open Sky" MRI



REFERENCE SITES



DUBAI

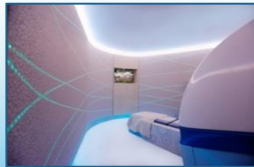

LONDON



VANCOUVER



EDMONTON



NAPOLI

MgB2 IS MOVING THE HORIZON OF IMAGING TECHNOLOGY



SMART

- Allows revolutionary “open sky” magnet design.
- Enables innovative clinical solutions in Imaging and Therapy.



SAFE

- Intrinsically “Quench free”.
- No Helium-related hazards and safety systems.
- Hassle free maintenance.



GREEN

- No Helium used.
- Friendly to the environment.
- Lower power consumption.
- Saving natural resources.



SIMPLE

- Makes revolutionary medical applications possible and easy.



ADVANCED

- Optimizes Healthcare by providing
- innovative clinical solutions
 - better patient outcomes
 - cost saving across the entire care cycle.

MGB2 IS THE CORE TECHNOLOGY OF THE MROpen SCANNER

THE WORLD'S ONLY 'OPEN SKY' UPRIGHT MRI SCANNER

WITH MgB₂ SUPERCONDUCTIVE MAGNET TECHNOLOGY

TECHNOLOGY

Friendly to the environment.
Quench-free safe operation. Lower power consumption. No use of natural resources.

MULTI-POSITION IMAGING

Perform MRI in the position of symptoms: standing, sitting, bending or lying down. Don't guess. Just see.

UPRIGHT IMAGING

Enables Upright MR Imaging of Spine and Joints in Weight Bearing Mode.



BEST MRI PATIENT EXPERIENCE

U-shaped design delivers unparalleled patient comfort.
No barrier between the patient and the environment.

HIGHEST PATIENT ACCEPTANCE

Claustrophobic, anxious, larger, elderly or disabled patients, or those who are in pain, are able to undergo the examination easily.

SPECIAL STUDIES & RESEARCH

Greatest versatility enables special MRI studies and clinical research: from dynamic studies, to imaging athletes with extreme ranges of flexion of the Spine and Joints.

THE LINAC-MR RADIOTHERAPY PROJECT

"SEEING. ADAPTING. TREATING."

Therapeutic Challenge

The Medical Physics Department of the University of Alberta, in collaboration with the Cancer Imaging and Therapy of Alberta Health Services and the University of Alberta, have developed devices.

1. The Linac-MR prototype is equipped with Paramed MRI unit's magnet, external markers.
2. Tumors can be treated without using MRI combined with a MRI scanner for real-time guidance of radiotherapy.
3. Strong reduction of "out-of-target" radiation dose to healthy tissues surrounding the tumor, greatly improving treatment outcome and quality of life.

www.mn.med.ualberta.ca/linac-mr/

RADIOTHERAPY

USING COLUMBUS MGB2 technology

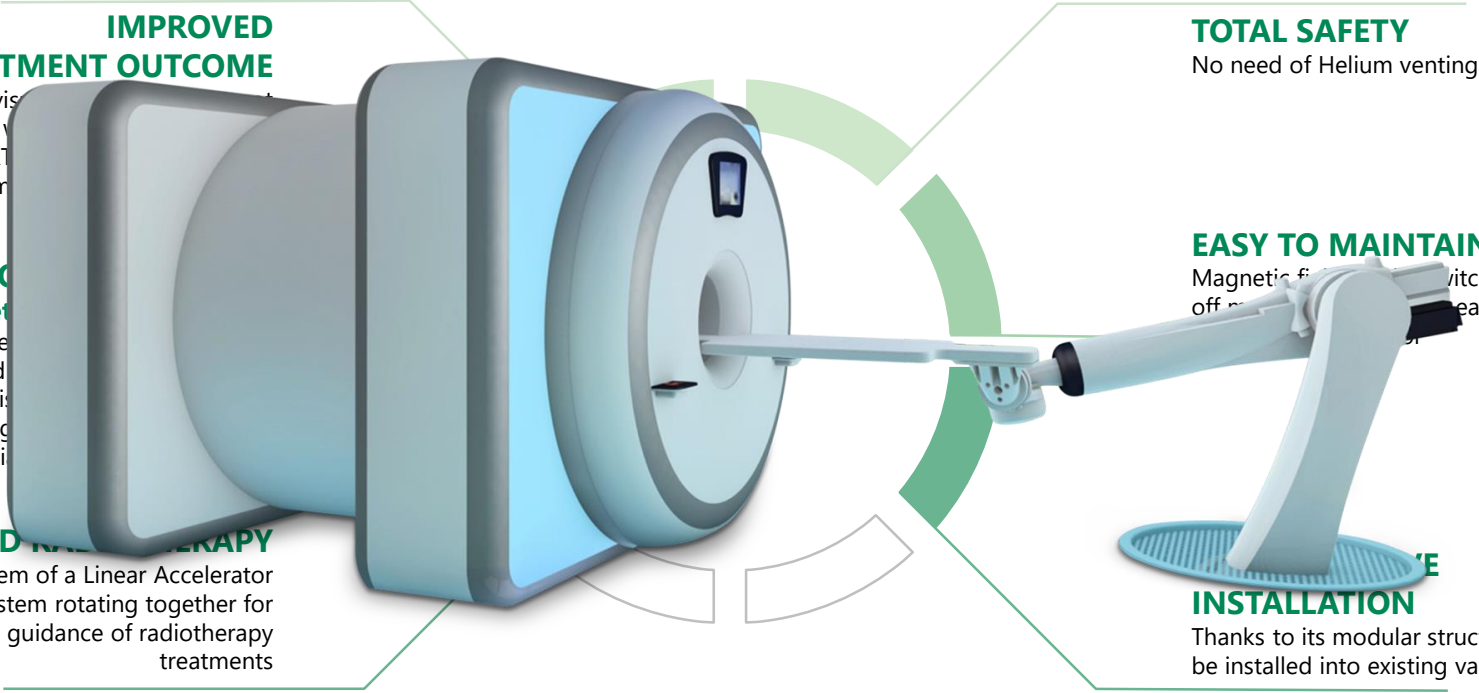

IMPROVED TREATMENT OUTCOME

It enables the vis...
easily imaged v...
based IGRT...
stom...

NO... (bet

The only syste...
to be delivered...
reducing tis...
enabling...
especi...

MR-GUIDED RADIOTHERAPY

Integrated System of a Linear Accelerator and a MRI system rotating together for real-time guidance of radiotherapy treatments

TOTAL SAFETY

No need of Helium venting

EASY TO MAINTAIN

Magnetic fi... switched off... easier on

EASY INSTALLATION

Thanks to its modular structure, it can be installed into existing vaults

